

PRODUCT NAME

Valve Monitor

MODEL NO.

ALS300PA23

DESCRIPTION OF THE PRODUCT

The ALS300PA23 series valve monitor is a rotary position indication device. Armed with inductive sensors, this device can sense mechanical position (on/off) of valve for remote PLC or PC indication. The visual indicator on the top of the device can also clearly display the valve position for local detection.



APPROVED BY

CE IP 67 NEMA 4.4X

WIRING DIAGRAM(3 Wire)

SPECIFICATIONS AND TECHNICAL DATA

Enclosure	Die-casting aluminum: O-ring sealed
Coating	Dichromate conversion with polyester powder coating
O-rings	Buna N
Environment	Type 4, 4X, IP67
Area Classification	Standard
Fasteners	Stainless steel
Shaft	Stainless steel Namur
Conduit Entries	Two 1/2" BSPP Also available with two 1/2" NPT, M20-1.5
Terminal Strip Contacts	8
Mounting Bracket	MB – 3.4: 30 x 80, 130 H:20, 30 (Carbon steel)
Temperature Rating	-20°C-85°C

Sensor:Two ALPS Inductive sensors (3 wire)

Model No.	PA23
Operating Voltage	10-30 VDC, <=150mA
Operating Temp.	-25°C-85°C



PNP NO(3 wire)

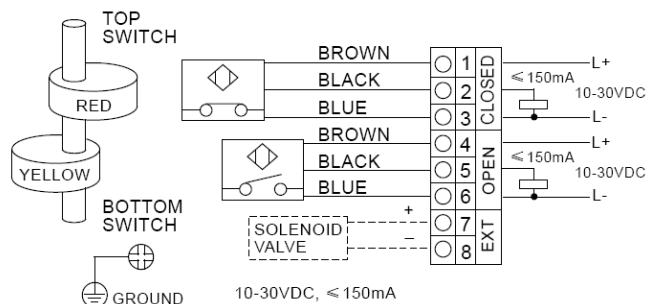

NPN NO(3 wire)

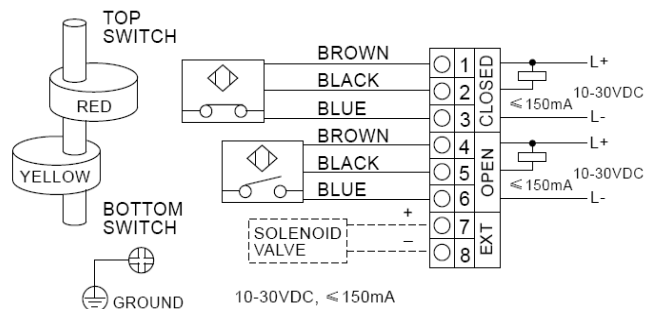

DRAWING AND DIMENSION

